

**INSTALLATION INSTRUCTIONS FOR
SPIRAL GAUGES 8680S10LLL
READ COMPLETELY BEFORE ATTEMPTING INSTALLATION**

These instructions are prepared to assist tradesmen and others generally familiar with liquid storage tank equipment. Most consumers are not qualified to perform the installation described below. If you have any questions concerning installation or operation of the gauge, contact Rochester Gauges, Intl. or one of our authorized distributors for assistance.

IS THE GAUGE RIGHT FOR YOUR APPLICATION ?

Gauges should only be installed in applications specifically approved by the manufacturer. Verify that the gauge is the proper gauge for your application prior to attempting installation. The gauge must be constructed of materials compatible with the liquid to be measured and the service environment.

These gauges are not intended for use in pressurized vessels.

IS THE GAUGE THE PROPER SIZE ?

As a general rule, the gauge should be sized to provide approximately 1/2" (13mm) clearance between the bottom of the tank and the lowest portion of the gauge when the gauge head is fully tightened into the mounting coupling.

NOTE:

During shipping the support or center shaft on this type of gauge may occasionally be slightly bent which may restrict free movement of the float throughout its travel. Before installation, raise and lower the float the entire length of the support. If any binding is encountered it is a simple matter to correct. At the point on the support where the float blinds, either the center shaft or one of the support wires will not be parallel to the other two. This can be corrected by bending the appropriate wire back into its proper position.

INSTALLATION

- A. Gauges are normally fastened to tank using a coupling which has previously been welded into the tank. Check coupling for correct dimensions and finish.
(See opposite side of this drawing for dimensions).
- B. Apply Teflon tape or other adequate pipe thread compound to gauge mounting threads.
- C. Carefully insert the support into and thru coupling being careful not to bend or damage support wires.
- D. Torque head to range listed below. Align head for proper orientation of dial.

CAUTION: Do not over torque. Over tightening may cause damage to head and threads.

GAUGE THREAD	DRY TORQUE
1-1/2" BSP	34-67 Nm (25-50 FT/LBS)

GAUGE REMOVAL WARNING

Should it appear necessary, for any reason, to remove the gauge from the tank, do not attempt removal unless under competent supervision with all due precautions taken against the hazards of escaping liquid or gas.

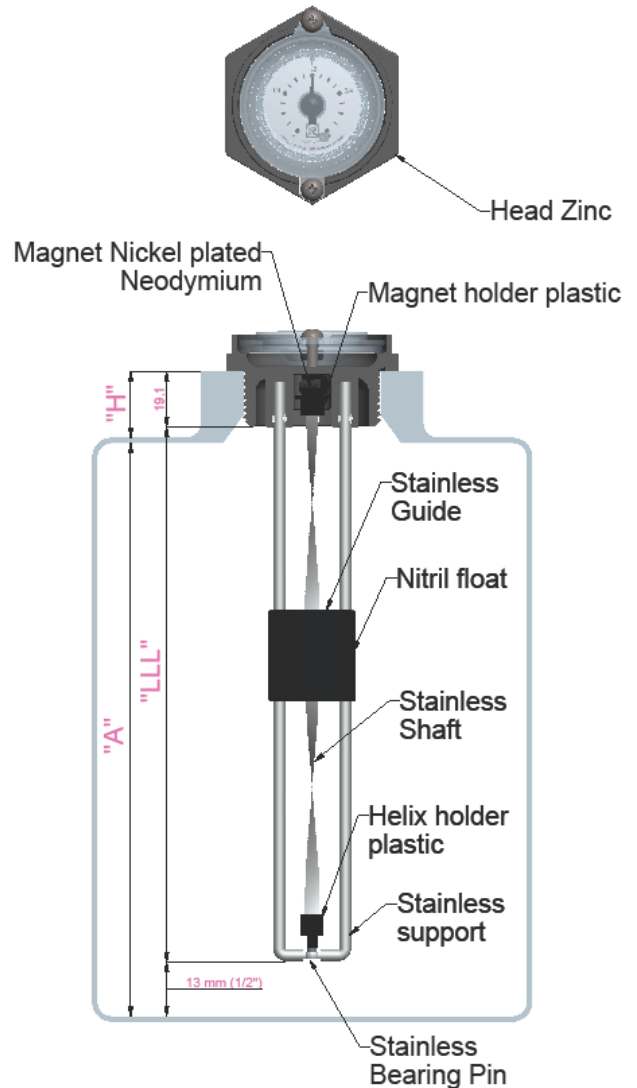

Whitworth Tapered Pipe Thread

DIN 2999 BSPT (British Standard Tapered Pipe)

Specifications of International Thread Standards

Whitworth Tapered Pipe Thread

Whitworth Pipe Thread for pipes and fittings. Parallel female thread and tapered male thread (taper 1 : 16).

An appropriate sealing compound can be used in the thread to ensure a leak-proof joint.

Male Thread Diameter	Female Thread Diameter	Pipe Minor Diameter mm	Pipe Major Diameter mm	Tapping Drill Size mm	TPI	Pitch mm
R 1/16	Rp 1/16	3	7,723	6,561	28	0,907
R 1/8	Rp 1/8	6	9,728	8,566	28	0,907
R 1/4	Rp 1/4	8	13,157	11,445	19	1,337
R 3/8	Rp 3/8	10	16,662	14,950	19	1,337
R 1/2	Rp 1/2	15	20,995	18,631	14	1,814
R 3/4	Rp 3/4	20	26,441	24,117	14	1,814
R 1	Rp 1	25	33,249	30,291	11	2,309
R 1 1/4	Rp 1 1/4	32	41,910	38,952	11	2,309
R 1 1/2	Rp 1 1/2	40	47,803	44,845	11	2,309
R 2	Rp 2	50	59,614	56,656	11	2,309
R 2 1/2	Rp 2 1/2	65	75,184	72,226	11	2,309
R 3	Rp 3	80	87,884	84,926	11	2,309
R 4	R 4	100	113,030	110,072	11	2,309
R 5	Rp 5	125	138,430	135,472	11	2,309
R 6	Rp 6	150	163,830	160,872	11	2,309

