



Application

These fuel senders are designed for top mounting in unpressurized aluminum, stainless steel, or plastic fuel tanks in all types of marine vessels. They include special features and protection from corrosion problems (internal and external to the fuel tanks) which make them the quality standard for the industry.

General Information & Features

Standard configuration, with the lead hole at 12:00, has the float arm swinging at 3:00.

The float arm on this sender is 24" [609mm] long measured from the pivot point allowing it to be cut to an appropriate length to gauge any tank depth from 6" [152mm] to 25" [635mm]. The float and the washers are furnished unassembled to the float arm. The cutting and crimping process is to be done prior to the float assembly. See DS-1235.

The fuel sender is equipped with a thick film resistance card with a range of 240 to 30Ω.

The recommended gasket for use under the head is made of nitrile rubber and must be ordered separately under part number 0015-00716.



Part #	Market	Float Type	Tank Depth
8341-F7000	OEM	Flat	6" - 19 1/2"
8341-R7000		Round	6" - 25"
8341-A7000	After Market	Flat	6" - 19 1/2"

† See DS-1325

-F7000
-A7000



OR

-R7000

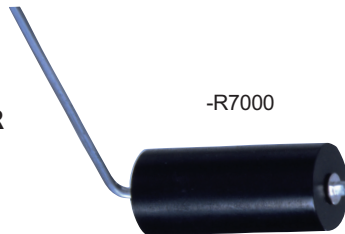

Marine Fuel Level Sender

8341-7000

Marine Fuel Level Sender

[METRIC]

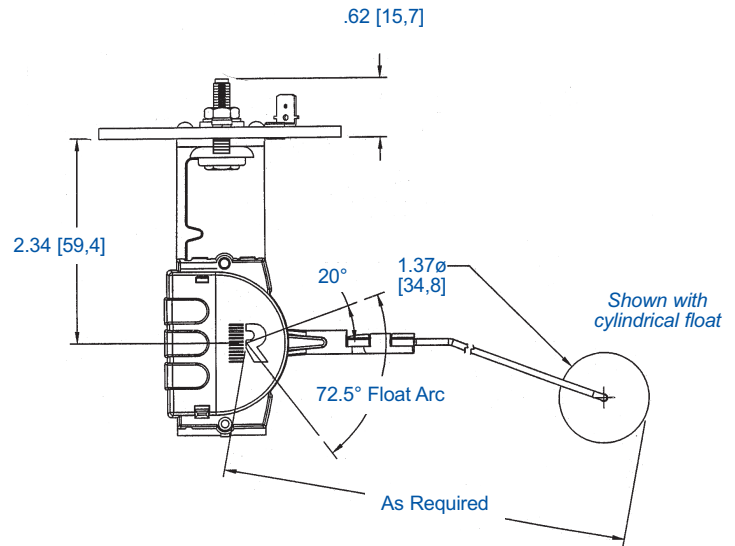
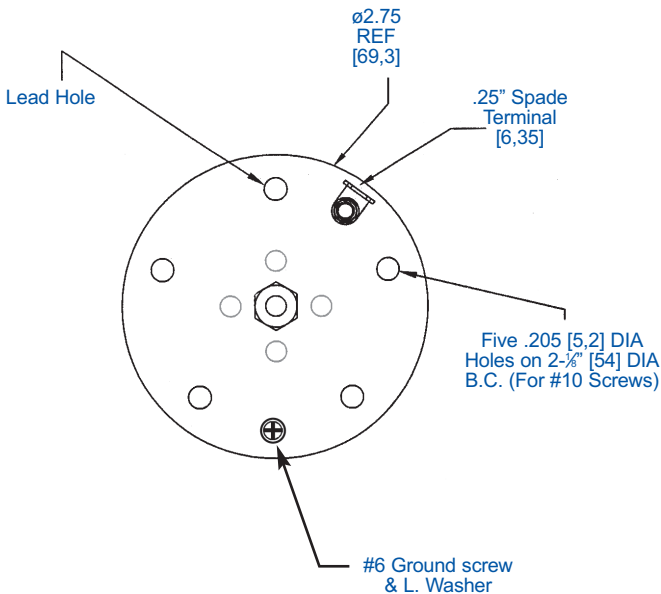

General Specifications*

Mounting

Recommended for top mounting only

Accuracy

Resistance accuracy at empty +0%, -3%; at full +3%, -0% of full scale. System accuracy depends upon proper fitting of sender to tank, tank shape and indicator calibration.

Temperature

-40°F to 158°F, -40 to 70C.

Vibration

Qualified at 2g, 40 HZ.

Power

0.5 Watts maximum.

Leak Test

Passes 16 PSIG [1,1 Bar] test.

Note: For installation instructions see DS-953 (data sheet).

Materials of Construction*

Head

Tempered aluminum w/gold irridite finish, made to SAE pattern for fuel senders (2 1/8" bolt circle for 5 #10 screws)

Support

Tempered aluminum w/gold irridite finish

Card Holder & Head Insulator

Injection-molded thermoset plastic

Ground Strap & Signal Strap

Tin-plated brass or copper

Center Stud, Nuts & Washers

Brass

Resistance Element

Thick Film

Contact Spring

Plated beryllium copper

Contact

Silver

Float

Nitrile rubber (cylindrical or rectangular/flat)

Stainless steel float wire

Ground Screw and Lockwasher

Stainless steel

* Materials and specifications are subject to change without notice.
Pressure ratings subject to change due to temperature and other environmental considerations.