



## GAUGE SERIE 6200

**APPLICATION :** The 6200 series gauges are widely used to indicate liquid levels of fuels, hydraulic fluids, lube oils, liquified gases such as propane, butane, ammonia etc...

The 6200 series gauges are used for tank diameter up to 2000mm and tank pressure up to 25 bar. Float is counterbalanced for low specific gravity fluids. Gauge can be equipped with direct reading dial, twinsite or switch.

### STANDARD MATERIAL OF CONSTRUCTION :

- Head: aluminium
- Gear housing: plastic
- Centershaft, support tube, float rod: aluminium
- Gears, cross stud, bearings: stainless steel
- Drive magnet: alnico, NdFeB grade 45 –Nickel plated finish
- Float: nitrile rubber
- Gasket: buna-n
- Counterweight: lead

**OPTIONS:** Head : junior brass head: prefix B

Float : nitrophil float (3 bar max. press.) prefix C  
aluminium

stainless steel float prefix A

gear housing : aluminium

Plastic or Metal cover for head



### MOUNTING POSITION :

Gauges of serie 6200 can be manufactured for any mounting position.

- Vertical : top mounted 1
- Horizontal : end mounted 2
- Horizontal : side mounted 3
- Angle : angle mounted 4

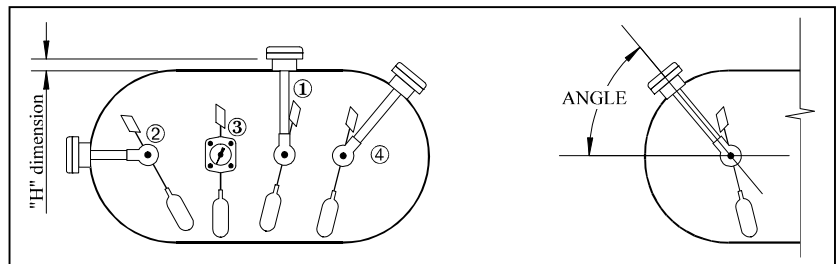

(angle for angle mounted gauge is specified from horizontal, positive above horizontal, negative below horizontal)

### CERTIFICATION :

Those gauges serie 6200 are in accordance with European Directive PED 97/23/CE for LPG, ammonia for maximum pressure 25 bar and temperature  $-20^{\circ}$  to  $+60^{\circ}$ C

Others: on request after risk analysis.

They have been certified by APRAGAZ, notified body 0029, under n° 02/BE/329

Subject to change without notice

6/10

**ROCHESTER GAUGES INTERNATIONAL S.A.**

Z.I. WAVRE NORD - Av. Lavoisier, 6 - 1300 WAVRE (Belgium)

Tél. (010) 24.10.10 - Fax (010) 22.81.39

**MOUNTING :**

**Junior:** (4) screws 1/4"-28\*7/8" or M6/25 mm on 51.6 mm bolt circle.

**Senior:** (4) screws 5/16"-24\*7/8" or M8/25 mm on 63.5 mm bolt circle.

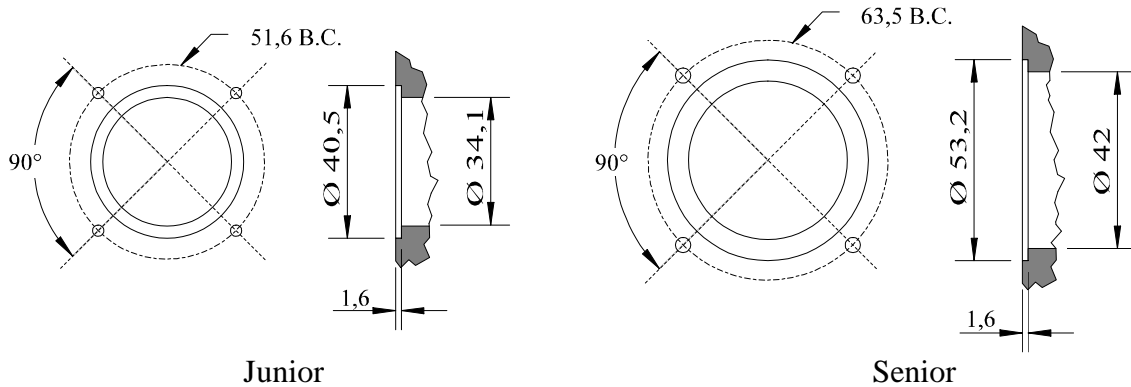

MODEL NUMBER	MOUNTING	GAUGE TYPE	DIAL TYPE
6240	TOP	SENIOR	TWINSITE : refer to twinsite section for model available
6241	TOP	JUNIOR	
6243	HORIZ. OR ANGLE	SENIOR	
6244	HORIZ. OR ANGLE	JUNIOR	
6250	TOP	SENIOR	SWITCH : refer to switch section for model available
6251	TOP	JUNIOR	
6253	HORIZ. OR ANGLE	SENIOR	
6254	HORIZ. OR ANGLE	JUNIOR	
6260	TOP	SENIOR	Side reading
6280	TOP	SENIOR	50 mm dial
6281	TOP	JUNIOR	40 mm dial
6283	HORIZ. OR ANGLE	SENIOR	50 mm dial
6284	HORIZ. OR ANGLE	JUNIOR	40 mm dial
6290	TOP	SENIOR	100 mm dial
6293	HORIZ. OR ANGLE	SENIOR	100 mm dial (**)

(\*\*) refer to dial section.

**ORDERING INFORMATION:**

A. For cylindrical horizontal tank specify:

- gauge model number
- liquid to be gauged with its density, tank design pressure
- working pressure and temperature
- mounting position
- riser dimension (distance between gauge gasket seat and tank wall)
- outside and inside diameter
- shape of dished end for end mounting gauge
- tank drawing is required for gauge angle mounted on dished end of tank

B. For vertical cylindrical tank specify:

- same information as in A
- dimension of cylindrical part and dimension of dished ends
- position of gauge from bottom of tank for side mounted gauge; position of gauge from vertical centerline of tank for top mounted gauge
- total tank content
- portion of tank to be gauged

C. For non cylindrical tank specify:

- same information as in A
- tank drawing